

PICC 产品质量由中国人民保险公司承保
PRODUCTS QUALITY INSURED BY PEOPLES INSURANCE CORPORATION OF CHINA

CE GS ISO9002



LIHUA LIFTING

河北力华起重机械制造有限公司

一流的管理 一流的质量 一流的诚信 一流的服务
First Management First Quality First Honest First Service



地址：河北省保定市清苑区东吕工业区

电话：0312-8151159

传真：0312-8152698

手机：13803263589

网址：www.lihuaqzjx.com

Add: Donglu Industrial Zone, Qingyuan District,
Baoding city, Hebei Province

Tel: 0312-8151159

Fax: 0312-8152698

Mob: 13803263589

Http://www.lihuaqzjx.com

中国 • 河北
China • Hebei



COMPANY

Profile

企业简介

河北力华起重机械制造有限公司位于中国专业从事生产制造和销售的起重之乡河北省清苑县。我公司从事生产起重设备已有三十年的经验，主要生产电动葫芦，手拉葫芦，手扳葫芦，G80 链条，手推手拉跑车，吊装带，吊索具等。产品出口百余国家，久负盛名。

公司以“科技为先导，质量为生存，信誉求发展，管理求效益”的经营宗旨，建立起一套严格的管理制度，完善的质量保证体系和检测手段。凭着过硬的质量，良好的服务和极好的信誉，赢得了众多客户的信任！

我公司于1995被国家机电部授予“全国质量管理达标企业”称号，于2000年通过TUV的CE，GS安全认证及2001年通过ISO 9001国家质量体系认证。我司产品由中国人民保险公司质量承保！

力华起重真诚欢迎国内外友人莅临指导，互助合作，共赢未来！

Hebei Lihua Hoisting Machinery Manufacturing Co.,Ltd

Hebei Lihua Hoisting Machinery Manufacturing Co.,Ltd is located in the hometown of hoisting products Hebei Province Qingyuan County. Lihua Hoisting has about 30 years experience in produce hoisting products, including electric hoist, chain hoist, lever hoist, G80 chains, manual trolley, lifting slings etc. And our products exported to most countries of world with a long great reputation. Our company set up a series of strict framework of management and perfect system of quality guaranty, as well as check methods, in the spirit of “regarding science and technology as previous guidelines, existing through great quality, developing through credit, seeking benefit by strict management” . With excellent quality, good service and excellent reputation, we win all customers trust.



Safety is our commitment
安全是我们的承诺

CE GS ISO9002 PICC

CATALOG

产品型录

Product Catalog

- 微型电动葫芦 MINIATURE ELECTRIC HOIST
- 提升机吊运机绞盘 HOIST WINCH
- CD1电动葫芦 CD1 ELECTRIC HOIST
- 环链电动葫芦 LOOP CHAIN ELECTRIC HOIST
- 手拉葫芦 CHAIN
- 手扳葫芦 LEVER HOIST
- 链条索具 CHAIN RIGGING
- 搬运车 叉车 A MOVING TRUCK FORK LIFT
- 电子吊秤 平衡器 ELECTRONIC CRANE BALANCE BALANCER
- 起重永磁吸盘 LIFTING PERMANENT MAGNET CHUCK
- 机械千斤顶 MECHANICAL JACK
- 单轨行车 MONORAIL CAR
- 吊装带 LIFTING BELT
- 起重吊钳 DERRICK PLIERS
- 起重滑车 HOIST



国标微型电动葫芦

National standard micro electric hoist



PA200

额定电压(v)	Rated Volt(v)	220/230
输入功率(w)	Input Power(w)	450W
额定起重量(kg)	Rated Lifting Weight(kg)	100/200 kg
提升速度(m/min)	Lifting Speed(m/min)	10/5
提升高度(m)	Lifting Height(m)	12m
每件数量(PCS)	Qty/CTN(PCS)	2台
包装尺寸(cm)	Packing Dimension(cm)	36 x 14 x 22
单台毛重/净重(kg)	G W/N.W.(kg)	11.5/11



PA250

额定电压(v)	Rated Volt(v)	220/230
输入功率(w)	Input Power(w)	500W
额定起重量(kg)	Rated Lifting Weight(kg)	125/250 kg
提升速度(m/min)	Lifting Speed(m/min)	10/5
提升高度(m)	Lifting Height(m)	12m
每件数量(PCS)	Qty/CTN(PCS)	2台
包装尺寸(cm)	Packing Dimension(cm)	36 x 14 x 22
单台毛重/净重(kg)	G W/N.W.(kg)	11.7/11.2



PA300

额定电压(v)	Rated Volt(v)	220/230
输入功率(w)	Input Power(w)	550W
额定起重量(kg)	Rated Lifting Weight(kg)	150/300 kg
提升速度(m/min)	Lifting Speed(m/min)	10/5
提升高度(m)	Lifting Height(m)	12m
每件数量(PCS)	Qty/CTN(PCS)	2台
包装尺寸(cm)	Packing Dimension(cm)	36 x 14 x 22
单台毛重/净重(kg)	G W/N.W.(kg)	12.5/12



PA400

额定电压(v)	Rated Volt(v)	220/230
输入功率(w)	Input Power(w)	760W
额定起重量(kg)	Rated Lifting Weight(kg)	200/400 kg
提升速度(m/min)	Lifting Speed(m/min)	10/5
提升高度(m)	Lifting Height(m)	12m
每件数量(PCS)	Qty/CTN(PCS)	2台
包装尺寸(cm)	Packing Dimension(cm)	42 x 15 x 25
单台毛重/净重(kg)	G W/N.W.(kg)	15.5/15



PA500

额定电压(v)	Rated Volt(v)	220/230
输入功率(w)	Input Power(w)	920W
额定起重量(kg)	Rated Lifting Weight(kg)	250/500 kg
提升速度(m/min)	Lifting Speed(m/min)	10/5
提升高度(m)	Lifting Height(m)	12m
每件数量(PCS)	Qty/CTN(PCS)	2台
包装尺寸(cm)	Packing Dimension(cm)	42 × 15 × 25
单台毛重/净重(kg)	G W/N.W.(kg)	16/15.5



PA600

额定电压(v)	Rated Volt(v)	220/230
输入功率(w)	Input Power(w)	1100W
额定起重量(kg)	Rated Lifting Weight(kg)	300/600 kg
提升速度(m/min)	Lifting Speed(m/min)	10/5
提升高度(m)	Lifting Height(m)	12m
每件数量(PCS)	Qty/CTN(PCS)	2台
包装尺寸(cm)	Packing Dimension(cm)	42 × 15 × 25
单台毛重/净重(kg)	G W/N.W.(kg)	17/16.5



PA800

额定电压(v)	Rated Volt(v)	220/230
输入功率(w)	Input Power(w)	1400W
额定起重量(kg)	Rated Lifting Weight(kg)	400/800 kg
提升速度(m/min)	Lifting Speed(m/min)	10/5
提升高度(m)	Lifting Height(m)	12m
每件数量(PCS)	Qty/CTN(PCS)	2台
包装尺寸(cm)	Packing Dimension(cm)	42 × 15 × 25
单台毛重/净重(kg)	G W/N.W.(kg)	18.5/18



PA1000

额定电压(v)	Rated Volt(v)	220/230
输入功率(w)	Input Power(w)	1650W
额定起重量(kg)	Rated Lifting Weight(kg)	495/990 kg
提升速度(m/min)	Lifting Speed(m/min)	10/5
提升高度(m)	Lifting Height(m)	12m
每件数量(PCS)	Qty/CTN(PCS)	1台
包装尺寸(cm)	Packing Dimension(cm)	55 × 24 × 31
单台毛重/净重(kg)	G W/N.W.(kg)	29.5/28.5



PA1200

额定电压(v)	Rated Volt(v)	220/230
输入功率(w)	Input Power(w)	1800W
额定起重量(kg)	Rated Lifting Weight(kg)	550/1200 kg
提升速度(m/min)	Lifting Speed(m/min)	10/5
提升高度(m)	Lifting Height(m)	12m
每件数量(PCS)	Qty/CTN(PCS)	1台
包装尺寸(cm)	Packing Dimension(cm)	55 × 24 × 31
单台毛重/净重(kg)	G W/N.W.(kg)	30.5/29.5



美标微型电动葫芦

American standard miniature electric hoist



PA200

额定电压(v)	Rated Volt(v)	110/120-60Hz
输入功率(w)	Input Power(w)	500W
额定起重量(kg)	Rated Lifting Weight(kg)	100/200 kg
提升速度(m/min)	Lifting Speed(m/min)	10/5
提升高度(m)	Lifting Height(m)	12m
每件数量(PCS)	Qty/CTN(PCS)	2台
包装尺寸(cm)	Packing Dimension(cm)	36 × 14 × 22
单台毛重/净重(kg)	G W/N.W.(kg)	11.5/11



PA250

额定电压(v)	Rated Volt(v)	110/120-60Hz
输入功率(w)	Input Power(w)	550W
额定起重量(kg)	Rated Lifting Weight(kg)	125/250 kg
提升速度(m/min)	Lifting Speed(m/min)	10/5
提升高度(m)	Lifting Height(m)	12m
每件数量(PCS)	Qty/CTN(PCS)	2台
包装尺寸(cm)	Packing Dimension(cm)	36 × 14 × 22
单台毛重/净重(kg)	G W/N.W.(kg)	11.7/11.2



PA300

额定电压(v)	Rated Volt(v)	110/120-60Hz
输入功率(w)	Input Power(w)	600W
额定起重量(kg)	Rated Lifting Weight(kg)	150/300 kg
提升速度(m/min)	Lifting Speed(m/min)	10/5
提升高度(m)	Lifting Height(m)	12m
每件数量(PCS)	Qty/CTN(PCS)	2台
包装尺寸(cm)	Packing Dimension(cm)	36 × 14 × 22
单台毛重/净重(kg)	G W/N.W.(kg)	12.5/12



PA400

额定电压(v)	Rated Volt(v)	110/120-60Hz
输入功率(w)	Input Power(w)	820W
额定起重量(kg)	Rated Lifting Weight(kg)	200/400 kg
提升速度(m/min)	Lifting Speed(m/min)	10/5
提升高度(m)	Lifting Height(m)	12m
每件数量(PCS)	Qty/CTN(PCS)	2台
包装尺寸(cm)	Packing Dimension(cm)	42 × 15 × 25
单台毛重/净重(kg)	G W/N.W.(kg)	15.5/15



PA500

额定电压(v)	Rated Volt(v)	110/120-60Hz
输入功率(w)	Input Power(w)	990W
额定起重量(kg)	Rated Lifting Weight(kg)	250/500 kg
提升速度(m/min)	Lifting Speed(m/min)	10/5
提升高度(m)	Lifting Height(m)	12m
每件数量(PCS)	Qty/CTN(PCS)	2台
包装尺寸(cm)	Packing Dimension(cm)	42 x 15 x 25
单台毛重/净重(kg)	G W/N.W.(kg)	16/15.5



PA600

额定电压(v)	Rated Volt(v)	110/120-60Hz
输入功率(w)	Input Power(w)	1150W
额定起重量(kg)	Rated Lifting Weight(kg)	300/600 kg
提升速度(m/min)	Lifting Speed(m/min)	10/5
提升高度(m)	Lifting Height(m)	12m
每件数量(PCS)	Qty/CTN(PCS)	2台
包装尺寸(cm)	Packing Dimension(cm)	42 x 15 x 25
单台毛重/净重(kg)	G W/N.W.(kg)	17/16.5



PA800

额定电压(v)	Rated Volt(v)	110/120-60Hz
输入功率(w)	Input Power(w)	1500W
额定起重量(kg)	Rated Lifting Weight(kg)	400/800 kg
提升速度(m/min)	Lifting Speed(m/min)	10/5
提升高度(m)	Lifting Height(m)	12m
每件数量(PCS)	Qty/CTN(PCS)	2台
包装尺寸(cm)	Packing Dimension(cm)	42 x 15 x 25
单台毛重/净重(kg)	G W/N.W.(kg)	18.5/18



PA1000

额定电压(v)	Rated Volt(v)	110/120-60Hz
输入功率(w)	Input Power(w)	1650W
额定起重量(kg)	Rated Lifting Weight(kg)	500/1000 kg
提升速度(m/min)	Lifting Speed(m/min)	10/5
提升高度(m)	Lifting Height(m)	12m
每件数量(PCS)	Qty/CTN(PCS)	1台
包装尺寸(cm)	Packing Dimension(cm)	55 x 24 x 31
单台毛重/净重(kg)	G W/N.W.(kg)	29.5/28.5



PA1200

额定电压(v)	Rated Volt(v)	110/120-60Hz
输入功率(w)	Input Power(w)	2000W
额定起重量(kg)	Rated Lifting Weight(kg)	600/1200 kg
提升速度(m/min)	Lifting Speed(m/min)	10/5
提升高度(m)	Lifting Height(m)	12m
每件数量(PCS)	Qty/CTN(PCS)	1台
包装尺寸(cm)	Packing Dimension(cm)	55 x 24 x 31
单台毛重/净重(kg)	G W/N.W.(kg)	30.5/29.5



欧标微型电动葫芦

European standard micro electric hoist



PA200

额定电压(v)	Rated Volt(v)	220/230
输入功率(w)	Input Power(w)	450W
额定起重量(kg)	Rated Lifting Weight(kg)	100/200 kg
提升速度(m/min)	Lifting Speed(m/min)	10/5
提升高度(m)	Lifting Height(m)	12m
每件数量(PCS)	Qty/CTN(PCS)	2台
包装尺寸(cm)	Packing Dimension(cm)	36 x 14 x 22
单台毛重/净重(kg)	G W/N.W.(kg)	11.5/11



PA250

额定电压(v)	Rated Volt(v)	220/230
输入功率(w)	Input Power(w)	500W
额定起重量(kg)	Rated Lifting Weight(kg)	125/250 kg
提升速度(m/min)	Lifting Speed(m/min)	10/5
提升高度(m)	Lifting Height(m)	12m
每件数量(PCS)	Qty/CTN(PCS)	2台
包装尺寸(cm)	Packing Dimension(cm)	36 x 14 x 22
单台毛重/净重(kg)	G W/N.W.(kg)	11.7/11.2



PA300

额定电压(v)	Rated Volt(v)	220/230
输入功率(w)	Input Power(w)	550W
额定起重量(kg)	Rated Lifting Weight(kg)	150/300 kg
提升速度(m/min)	Lifting Speed(m/min)	10/5
提升高度(m)	Lifting Height(m)	12m
每件数量(PCS)	Qty/CTN(PCS)	2台
包装尺寸(cm)	Packing Dimension(cm)	36 x 14 x 22
单台毛重/净重(kg)	G W/N.W.(kg)	12.5/12



PA400

额定电压(v)	Rated Volt(v)	220/230
输入功率(w)	Input Power(w)	760W
额定起重量(kg)	Rated Lifting Weight(kg)	200/400 kg
提升速度(m/min)	Lifting Speed(m/min)	10/5
提升高度(m)	Lifting Height(m)	12m
每件数量(PCS)	Qty/CTN(PCS)	2台
包装尺寸(cm)	Packing Dimension(cm)	42 x 15 x 25
单台毛重/净重(kg)	G W/N.W.(kg)	15.5/15



PA500

额定电压(v)	Rated Volt(v)	220/230
输入功率(w)	Input Power(w)	920W
额定起重量(kg)	Rated Lifting Weight(kg)	250/500 kg
提升速度(m/min)	Lifting Speed(m/min)	10/5
提升高度(m)	Lifting Height(m)	12m
每件数量(PCS)	Qty/CTN(PCS)	2台
包装尺寸(cm)	Packing Dimension(cm)	42 x 15 x 25
单台毛重/净重(kg)	G W/N.W.(kg)	16/15.5



PA600

额定电压(v)	Rated Volt(v)	220/230
输入功率(w)	Input Power(w)	1100W
额定起重量(kg)	Rated Lifting Weight(kg)	300/600 kg
提升速度(m/min)	Lifting Speed(m/min)	10/5
提升高度(m)	Lifting Height(m)	12m
每件数量(PCS)	Qty/CTN(PCS)	2台
包装尺寸(cm)	Packing Dimension(cm)	42 x 15 x 25
单台毛重/净重(kg)	G W/N.W.(kg)	17/16.5



PA800

额定电压(v)	Rated Volt(v)	220/230
输入功率(w)	Input Power(w)	1400W
额定起重量(kg)	Rated Lifting Weight(kg)	400/800 kg
提升速度(m/min)	Lifting Speed(m/min)	10/5
提升高度(m)	Lifting Height(m)	12m
每件数量(PCS)	Qty/CTN(PCS)	2台
包装尺寸(cm)	Packing Dimension(cm)	42 x 15 x 25
单台毛重/净重(kg)	G W/N.W.(kg)	18.5/18



PA1000

额定电压(v)	Rated Volt(v)	220/230
输入功率(w)	Input Power(w)	1650W
额定起重量(kg)	Rated Lifting Weight(kg)	495/990 kg
提升速度(m/min)	Lifting Speed(m/min)	10/5
提升高度(m)	Lifting Height(m)	12m
每件数量(PCS)	Qty/CTN(PCS)	1台
包装尺寸(cm)	Packing Dimension(cm)	55 x 24 x 31
单台毛重/净重(kg)	G W/N.W.(kg)	29.5/28.5



PA1200

额定电压(v)	Rated Volt(v)	220/230
输入功率(w)	Input Power(w)	1800W
额定起重量(kg)	Rated Lifting Weight(kg)	550/1200 kg
提升速度(m/min)	Lifting Speed(m/min)	10/5
提升高度(m)	Lifting Height(m)	12m
每件数量(PCS)	Qty/CTN(PCS)	1台
包装尺寸(cm)	Packing Dimension(cm)	55 x 24 x 31
单台毛重/净重(kg)	G W/N.W.(kg)	30.5/29.5

起重吊运机 Hoisting machine

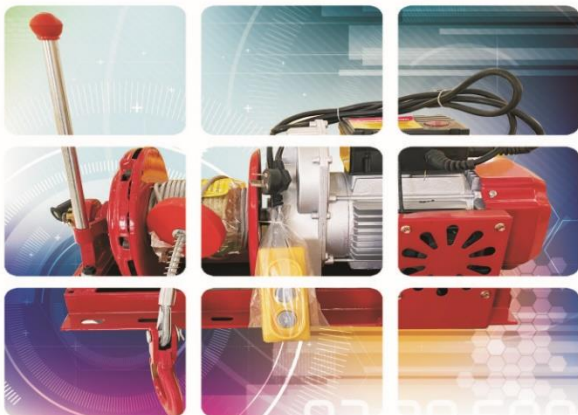

吊运机基本参数 Basic parameters of hoist

型号	额定电压	输入功率	额定起重量	提升速度	提升高度
YBDY-1200	220/230-50Hz	1800W	600kg	14	18m
YBDY-1000	220/230-50Hz	1650W	500kg	14	18m
YBDY-800	220/230-50Hz	1500W	400kg	14	18m
DY-1000	220/230-50Hz	1650W	500kg	14	18m
DY-800	220/230-50Hz	1500W	400kg	14	18m

室内外全角型小吊机(220V) Small indoor/outdoor full Angle crane (220V)



特点

可以拆装, 携带方便, 能360度旋转, 配有220V傍磁刹车电机, 主机带有手动制动器和离合装置, 可以实现快速下降, 特别适合高层楼房使用。

The characteristics of

Can be disassembled and installed, easy to carry, can rotate 360 degrees, equipped with 220V magnetic brake motor, the main machine with Manual brake and clutch device, can achieve rapid descent, especially suitable for high-rise buildings.

技术参数

Technical parameters

型号	YL300/YL400
额定电	220V
额定功率	1.5kw/1.6kw
额定频率	50-60Hz
钢丝绳长度	30m
钢丝绳直径	5.0mm
起升重量	150kg/200kg
起升速度	15米/分钟



注意事项: 千万压好配重, 严禁无配重吊物, 最大起重量不超过350公斤。

Note: Please press the counterweight well. No lifting without counterweight.

Maximum lifting weight Not more than 350 kilograms.

多功能提升机(220V) Multi-function elevator(220V)

多功能电动提升机紧凑型设计, 安装方便; 经济实惠, 应用范围广。具有制动速度快, 体积小, 重量轻, 结构紧凑, 使用方便, 维修简便的特点。产品质量由中国人寿保险股份有限公司承保, 请放心使用。

应用领域:用于住宅建筑、吊灰砖、挖井提土、货场仓库、商场、饭店、个体作坊小型厂矿, 可作任何角度的搬移、起吊、装卸, 是目前国内最理想的小型提升工具, 还广泛用于中小型住宅, 高层建筑装修, 吊楼板、打井提土, 仓库厂吊物等单位或个人必备的常用机械。

Multi-function electric hoist compact design, easy installation; Economical and practical, wide application range. Has the braking speed, small volume, light weight, compact structure, convenient use, simple and easy for maintenance. Quality of the products by China life insurance co., LTD., please feel free to use.

Areas of application: used in residential construction, ash brick, digged soil, freight yard warehouse workshop of small factories, shopping malls, restaurants and individuals, can make any Angle of moving, lifting, loading and unloading, is currently the most ideal small promotion tool, also widely used in small and medium-sized residential, high-level architectural decoration, floor, soil drilling, warehouse, factory "and other unit or individual is necessary commonly used



基本参数The basic parameters

型号	额定电压	输入功率	额定起重量	提升速度	提升高度
MH-1T	220/230-50Hz	1600W	500/1000kg	12/6	30m
MH-1.5T	220/230-50Hz	2000W	750/1500kg	12/6	30m

电动车载绞盘 Electric car winch



电动绞盘是从汽车蓄电池中获得动力来驱动马达, 带动绞索。这种绞盘使用起来非常方便, 因为可以站在任何地方, 通过遥控器上的按钮来操纵绞盘。这种绞盘有一个优点, 那就是即使引擎发动不起来了, 只要电池里还有电, 就可以操纵绞盘。

The electric winch obtains power from the car battery to drive the motor and drive the noose. The capstan is very easy to use because you can stand from anywhere and use a knob on a remote control to control the capstan. One advantage of the capstan is that it can be operated as long as there is power in the battery, even if the engine fails to start.

Model	S6000(12/24V)
Rated line pull	6000LBS (2948kgs) single line
Motor	4.0kw/5.5hp (12V) series wound
Control	Remote switch, 12ft(3.7m)lead
Gear train	3 Stage Planetary
Gear train ratio	218:01:00
Clutch	Sliding Ring Gear
Braking Action	Automatic In-The-Drum
Drum Size	Φ2.5"×5.5" (Φ63.5×140mm)
Cable	9/32" of 66ft diameter (Φ7.2mm×20m)
Remote Control	Included
Battery	Recommended:650CCA minimum for winching
Battery Leads	2 gauge,72"(183mm)
Finish	Black powder coat
Overall Dimensions	17.9"×6.1"×8.6"(456mm×156mm×215mm)
Mounting Bolt Pattern	166.4mm×114.3mm
Weight	N.W.29kgs G.W.32Kgs
Packing size	49×19×34.5cm 1PC/CTN





环链电动葫芦 chain electric hoist

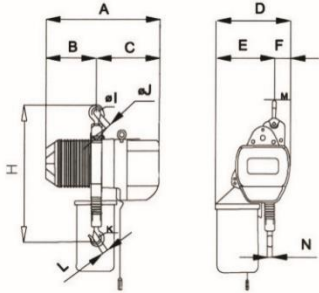

日本技术
双刹车系统
更安全更可靠

Japan Technology
Dual Braking System
Safe and More Reliable

性能参数 Specification

型号 Model	起重量 Capacity (t)	起升高度 Lifting height (m)	起升速度 Lifting Speed (m/Min)	运行速度 Running speed (m/Min)	起升电机 Lifting motor					运行电机 Running motor					工字钢 梁轨道 mm
					功率 Power (Kw)	转速 Rotate speed (r/min)	相数 Phase	电压 Voltage (V)	频率 Frequency (Hz/s)	功率 power (Kw)	转速 Rotate speed (r/min)	相数 phase	电压 Voltage (V)	频率 Frequency (Hz/s)	
DHL0.3-01	0.3	3/9	8.0	20	0.8	1440	3	380/220	50/60	0.4	1440	3	380/220	50/60	75-125
DHL0.5-01	0.5	3/9	8.0	20	0.8	1440	3	380/220	50/60	0.4	1440	3	380/220	50/60	75-125
DHL01-01	1	3/9	6.8	20	1.5	1440	3	380/220	50/60	0.4	1440	3	380/220	50/60	75-125
DHL01-02	2	3/9	3.4	20	1.5	1440	3	380/220	50/60	0.4	1440	3	380/220	50/60	75-125
DHL01-03	3	3/9	2.3	20	1.5	1440	3	380/220	50/60	0.4	1440	3	380/220	50/60	75-125
DHL02-01	2	3/9	9.4	20	3.0	1440	3	380/220	50/60	0.75	1440	3	380/220	50/60	100-150
DHL2.5-01	2.5	3/9	6.8	20	3.0	1440	3	380/220	50/60	0.75	1440	3	380/220	50/60	128-175
DHL03-01	3	3/9	5.6	20	3.0	1440	3	380/220	50/60	0.75	1440	3	380/220	50/60	128-175
DHL05-02	5	3/9	3.4	20	3.0	1440	3	380/220	50/60	0.75	1440	3	380/220	50/60	125-175
DHL7.5-03	7.5	3/9	2.3	13	3.0	1440	3	380/220	50/60	0.75×2	1440	3	380/220	50/60	150-300
DHL10-04	10	3/9	3.4	14	3.0×2	1440	3	380/220	50/60	0.75×2	1440	3	380/220	50/60	150-300
DHL15-06	15	3/9	2.3	14	3.0×2	1440	3	380/220	50/60	0.75×2	1440	3	380/220	50/60	150-300
DHL20-08	20	3/9	1.3	14	3.0×2	1440	3	380/220	50/60	0.75×2	1440	3	380/220	50/60	150-300
DHL25-08	25	3/9	1.3	14	3.0×2	1440	3	380/220	50/60	0.75×2	1440	3	380/220	50/60	150-300

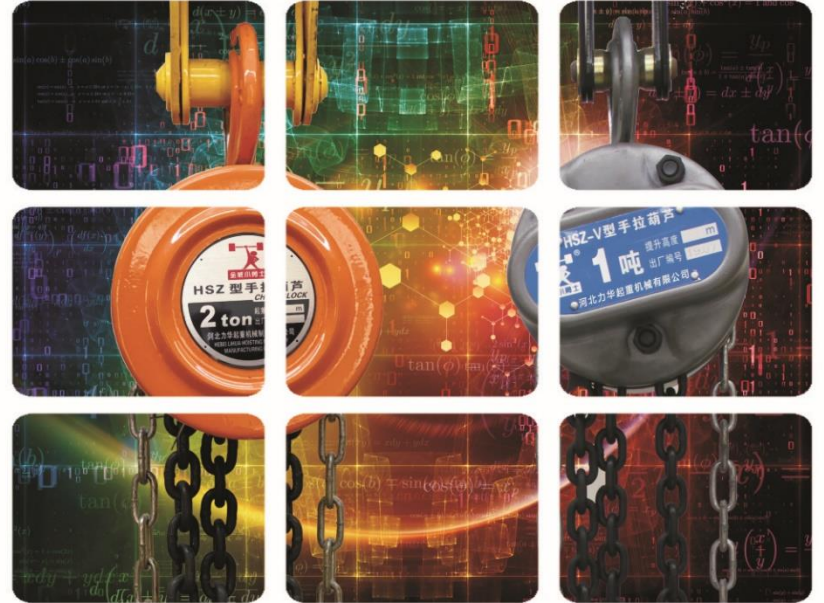

& HSZ-C型手拉葫芦

& HSZ型手拉葫芦

& HSZ-CB型手拉葫芦

& HSZ-VT型手拉葫芦

& HS-C型手拉葫芦

& HSZ-V型拉葫芦



HSZ-C 系列 手拉葫芦 HSZ-C Series chain hoist

HSZ-C型手拉葫芦是我公司在HSZ型手拉葫芦的基础上融合世界先进技术改良后的产品，除具有HSZ型手拉葫芦的传统特点外，更具有手拉力小，安全系数高，外形美观，适用性更高的手拉葫芦。

HSZ-C series chain hoist is improved from the base of HSZ type chain hoist, after absorbing the advanced technology of the world. Besides the traditional characteristics of HSZ chain hoist, it needs less hand-pull force, and it is safer, more beautiful and more applicable.

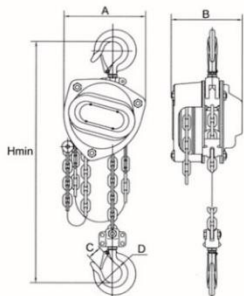
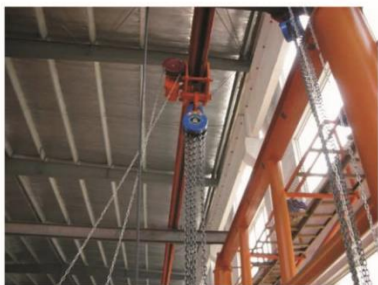

· 技术参数 Technical parameters

型号 Model	单位 Unit	HSZ-C $\frac{1}{2}$	HSZ-C1	HSZ-C1 $\frac{1}{2}$	HSZ-C2	HSZ-C3	HSZ-C5	HSZ-C10	HSZ-C20
起重量 Capacity	吨 t	0.5	1	1.5	2	3	5	10	20
标准起重高度 Standard lifting height	米 m	2.5	2.5	2.5	2.5	3	3	3	3
试验载荷 Test load	吨 t	0.75	1.5	2.25	3	4.5	7.5	12.5	25
两钩间最小距离 Hmin Headroom(hook to hook)Hmin	毫米 mm	255	306	368	444	486	616	700	1000
满载时手链拉力 Chainpull to lift full load	牛顿 N	221	304	343	314	343	383	392	392
起重链行数 No. of load chain fall lines		1	1	2	2	2	2	4	8
起重链条圆钢直径 Diameter of load chain	毫米 mm	6	6	6	6	8	10	10	10
		125	147	183	147	183	215	360.5	585
主要尺寸 Dimensions		111	126	141	126	141	163	163	191
		24	28	34	34	38	48	64	82
		134	154	192	154	192	224	224	224
净重 Net weight	公斤 kg	8	8	11	11	17	30	70	150
装箱毛重 Gross weight	公斤 kg	9	9	12	12	18	32	75	160
装箱尺寸 (长×宽×高) Packing measurement(L*W*H)	厘米 cm	27×22×18	27×22×18	31×22×18	31×22×18	35×26×20	41×30×23	54×46×22	70×45×75
起重高度每增加1米所增加的重量 Extra weight per meter of extra lift	公斤 kg	1.7	1.7	2.3	2.5	3.7	5.3	9.7	19.4

HSZ 型手拉葫芦 HSZ Series chain hoist

HSZ型手拉葫芦是一种使用简便、用途广泛，携带方便的手动起重机械，可用于工厂、矿山、农业、电力、建筑的生产施工，码头、船坞、仓库的机械安装、货物起吊、车辆装卸等，尤其适用于露天及无电源作业。

我公司产品按国家标准生产，采用对称排列二级齿轮转动结构，设计合理，用料考究，结构先进、外形美观、体积小、重量轻、手拉力小、机件强度高、韧性大，使用安全、经久耐用，产品至今畅销国内外，与世界名牌产品争高低。

HSZ series chain hoist is easy to use, easy to carry and widely used. It can be used in industry, mine, agriculture, electricity, construction of buildings, wharf and dock. And it can also be used in installing of machinery, lifting, loading and unloading in the warehouse, especially suitable to be used in the open air and the place without power source. We manufacture the products in accordance with national standard, use the symmetry arrayed two-stage gear-driven structure. The design is rational, the material is dainty, the structure is advanced, the appearance is beautiful, the volume is small, the weight is light, the component strength is big, and the toughness is high. It is safe and durable, widely used both at home and abroad, and competitive with the well-known brand all over the world.



· 技术参数 Technical parameters

型号 Model	单位 Unit	HS-C $\frac{1}{2}$	HSZ-1	HSZ-1 $\frac{1}{2}$	HSZ-2	HSZ-3	HSZ-5	HSZ-10	HSZ-20
起重量 Capacity	吨 t	0.5	1	1.5	2	3	5	10	20
标准起重高度 Standard lifting height	米 m	2.5	2.5	2.5	2.5	3	3	3	3
试验载荷 Test load	吨 t	0.75	1.5	2.25	3	4.5	7.5	12.5	25
两钩间最小距离 Hmin Headroom(hook to hook)Hmin	毫米 mm	270	270	368	444	486	616	700	1000
满载时手链拉力 Chainpull to lift full load	牛顿 N	225	309	343	314	343	383	392	392
起重链行数 No. of load chain fall lines		1	1	2	2	2	2	4	8
起重链条圆钢直径 Diameter of load chain	毫米 mm	6	6	6	6	8	10	10	10
		120	142	178	142	178	210	358	580
主要尺寸 Dimensions		108	122	139	122	139	162	162	189
		24	28	34	34	38	48	64	82
		120	142	178	142	178	210	210	210
净重 Net weight	公斤 kg	8	8	11	11	17	30	70	150
装箱毛重 Gross weight	公斤 kg	9	9	12	12	18	32	75	160
装箱尺寸 (长×宽×高) Packing measurement(L*W*H)	厘米 cm	27×22×18	27×22×18	31×22×18	31×22×18	35×26×20	41×30×23	54×46×22	70×45×75
起重高度每增加1米所增加的重量 Extra weight per meter of extra lift	公斤 kg	1.7	1.7	2.3	2.5	3.7	5.3	9.7	19.4

HSZ-CB 系列 手拉葫芦

HSZ-CB Series chain hoist

· 用途

HSZ-CB系列手拉葫芦是一种使用简易、携带方便的手动起重机械，适用于工厂、矿山、建筑工地、农业生产以及码头、船坞、仓库等用作安装机器、起吊货物和装卸车辆，尤其对于露天及无电源作业，更有其重要之功用。

HSZ-CB系列手拉葫芦可与各种手动单轨行车配套使用组成手动起重运输小车，适用于单轨架空运输，手动单梁桥式起重机和悬臂起重机上。

· 特点

HSZ-CB系列手拉葫芦在结构设计与使用性能上，具有五大特点：

- 1.使用安全可靠，维护简便。
- 2.机械效率高，手链拉力小。
- 3.自重较轻，便于携带。
- 4.外形美观、尺寸较小。
- 5.经久耐用。

· Use

HSZ-CB series chain block is one kind of use simple, carries the convenience the manual hoisting machinery, is suitable for the factory, the mine, the Construction site, the agricultural production as well as the wharf, the dock, the warehouse and so on serves as the mounting machinery, the hoisting up cargo and the loading and unloading vehicles, especially regarding open-air and non-power source work, has its important function.

HSZ-CB series chain block may manual lift heavy objects the traveling bogie with each kind of manual single track driving necessary use composition, is suitable is built on stilts the transportation in the single track, manual single beam bridge type hoist crane and on cantilever crane.

· Characteristic

HSZ-CB series chain block in the structural design and the operational performance, has five major characteristics:

1. uses safely reliable, maintains easily.
2. mechanical efficiency is high, the bracelet pulling force is small.
3. is self-possessed lightly, is advantageous carries.
4. contour is artistic, the size is small.
5. is durable.

· 技术参数 Technical parameters

产品型号 Model	HSZ-CB1T	HSZ-CB1.5T	HSZ-CB2T	HSZ-CB3T	HSZ-CB5T	HSZ-CB10T	
额定起重重量 Capacity (T)	1	1.5	2	3	5	10	
起升高度 Lifting Height (m)	2.5	2.5	2.5	3	3	3	
起重链条 Load Chain	行数No. of falls	1	2	2	2	4	
	规格 Demension	6 × 18	6 × 18	6 × 18	8 × 24	10 × 30	10 × 30
手拉力 Force of full load	250	265	335	372	360	380	
净重/毛重 N.W/G.W(KG)	A	14.5/15	16.5/17	19.5/20.1	32/34	41.1/43.6	75.7/79.1
	B	149	176	231	249	463	
外形尺寸 Demension (mm)	C	153	173	173	185	185	185
	D	29	35	35	39	49	54
	Hmin	41	51	51	49	67	75
		352	385	385	445	615	765
起升高度增加1m增加的重量 (KG) Additional weight per 1M lift	0.8	1.1	1.4	2.2	3.8	8.8	
装箱尺寸 (长×宽×高) Packing measurement(L*W*H)	厘米cm	26 × 17×21	36 × 21×25	36 × 21×25	43 × 21×24	42 × 28×30	58 × 48×25

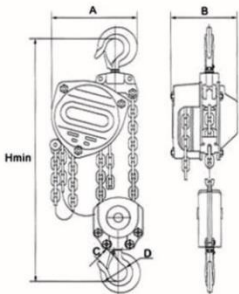

HSZ-VT 系列 手拉葫芦

HSZ-VT series chain block

· 用途

HSZ-VT系列手拉葫芦是一种使用简易、携带方便的手动起重机械，适用于工厂、矿山、建筑工地、农业生产以及码头、船坞、仓库等用作安装机器、起吊货物和装卸车辆，尤其对于露天及无电源作业，更有其重要之功用。

HSZ-VT系列手拉葫芦可与各种手动单轨行车配套使用组成手动起重运输小车，适用于单轨架空运输，手动单梁桥式起重机和悬臂起重机上。

· 特点

- 1.安全可靠，经久耐用。
- 2.性能好，使用方便，维修方便。
- 3.体积小携带方便。
- 4.结构合理，运行平稳，外形美观。

· Use

HSZ-VT series chain block is one kind of use simple, carries the convenience the manual hoisting machinery, is suitable for the factory, the mine, the Construction site, the agricultural production as well as the wharf, the dock, the warehouse and so on serves as the mounting machinery, the hoisting up cargo and the loading and unloading vehicles, especially regarding open-air and non-power source work, has its important function.

HSZ-VT series chain block may manual lift heavy objects the traveling bogie with each kind of manual single track driving necessary use composition, is suitable is built on stilts the transportation in the single track, manual single beam bridge type hoist crane and on cantilever crane.

· Characteristic

1. Safe, reliable, durable.
2. Performance, and easy to use and easy maintenance.
3. Are small and easy to carry.
4. Rational structure, running a smooth, beautiful appearance.

· 技术参数 Technical parameters

型号 Model	单位 Unit	VT1/2	VT1	VT1/2	VT2	VT3	VT5	VT10
起重重量 Capacity	吨 t	0.5	1	1.5	2	3	5	10
标准起重高度 Standard lifting height	米 m	2.5	2.5	2.5	3	3	3	3.5
试验载荷 Test load	吨 t	0.75	1.5	2.25	3	4.5	7.5	15
两钩间最小距离 Hmin Headroom(hook to hook)Hmin	毫米mm	285	315	340	380	475	600	700
满载时手链拉力 Chainpull to lift full load	牛顿 N	25	33	34	34	35	39	41
起重链条行数 No. of load chain fall lines		1	1	1	1	2	2	4
起重链条圆钢直径 Diameter of load chain	毫米mm	6.3	6.3	8	8	7.1	9	9
净重 Net weight	公斤kg	12	12	20	20	21	31	70
装箱毛重 Gross weight	公斤kg	13	13	21	21	23	39.5	76
装箱尺寸 (长×宽×高) Packing measurement(L*W*H)	厘米cm	30 × 20.5×20.5	30 × 20.5×20.5	34 × 21.5×28	34 × 21.5×28	38 × 26×20	38 × 29×22	53 × 24×47



手动葫芦系列



HSC-V 系列 手拉葫芦 HS-C Series chain hoist

HSC-V型手拉葫芦是我公司在HSZ型手拉葫芦的基础上融合世界先进技术改良后的产品，除具有HSZ型手拉葫芦的传统特点外，更具有手拉力小，安全系数高，外形美观，适用性更高的手拉葫芦。

HSC-V series chain hoist is improved from the base of HSZ type chain hoist, after absorbing the advanced technology of the world. Besides the traditional characteristics of HSZ chain hoist, it needs less hand-pull force, and it is safer, more beautiful and more applicable.

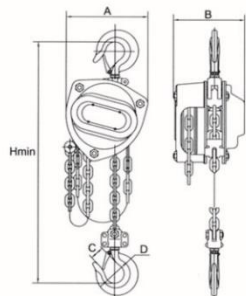

· 技术参数 Technical parameters

型号 Model	单位 Unit	HS-C1/2	HS-C1	HS-C1 1/2	HS-C2	HS-C3	HS-C5	HS-C10	HS-C20
起重量 Capacity	吨 t	0.5	1	1.5	2	3	5	10	20
标准起重高度 Standard lifting height	米 m	2.5	2.5	2.5	2.5	3	3	3	3
试验载荷 Test load	吨 t	0.75	1.5	2.25	3	4.5	7.5	12.5	25
两钩间最小距离 Hmin Headroom(hook to hook)Hmin	毫米 mm	255	306	368	444	486	616	700	1000
满载时手链拉力 Chainpull to lift full load	牛顿 N	221	304	343	314	343	383	392	392
起重链行数 No. of load chain fall lines		1	1	2	2	2	2	4	8
起重链条圆钢直径 Diameter of load chain	毫米 mm	6	6	6	6	6	8	10	10
		125	147	183	147	183	215	360.5	585
		111	126	141	126	141	163	163	191
		24	28	34	34	38	48	64	82
		134	154	192	154	192	224	224	224
净重 Net weight	公斤 kg	10	10	14	14	19	33	70	150
装箱毛重 Gross weight	公斤 kg	11	11	15	15	20	34	75	160
装箱尺寸 (长×宽×高) Packing measurement(L*W*H)	厘米 cm	26×28×20	26×28×20	30×20×17	30×20×17	40×28×20	45×29×23	54×46×22	70×45×75
起重高度每增加1米所增加的重量 Extra weight per meter of extra lift	公斤 kg	1.7	1.7	2.3	2.5	3.7	5.3	9.7	19.4

手动葫芦系列



HSZ-V 型手拉葫芦 HSZ-V Series chain hoist

HSZ-V型手拉葫芦是一种使用简便、用途广泛，携带方便的手动起重机械，可用于工厂、矿山、农业、电力、建筑的生产施工，码头、船坞、仓库的机械安装、货物起吊、车辆装卸等，尤其适用于露天及无电源作业。

我公司产品按国家标准生产，采用对称排列二级齿轮转动结构，设计合理，用料考究，结构先进、外形美观、体积小、重量轻、手拉力小、机件强度高、韧性大，使用安全、经久耐用，产品至今畅销国内外，与世界名牌产品争高低。

HSZ-V series chain hoist is easy to use, easy to carry and widely used. It can be used in industry, mine, agriculture, electricity, construction of buildings, wharf and dock. And it can also be used in installing of machinery, lifting, loading and unloading in the warehouse, especially suitable to be used in the open air and the place without power source. We manufacture the products in accordance with national standard, use the symmetry arrayed two-stage gear-driven structure. The design is rational, the material is dainty, the structure is advanced, the appearance is beautiful, the volume is small, the weight is light, the component strength is big, and the toughness is high. It is safe and durable, widely used both at home and abroad, and competitive with the well-known brand all over the world.



· 技术参数 Technical parameters

型号 Model	单位 Unit	HSZ-V1/2	HSZ-V1	HSZ-V1 1/2	HSZ-V2	HSZ-V3	HSZ-V5	HSZ-V10	HSZ-V20
起重量 Capacity	吨 t	0.5	1	1.5	2	3	5	10	20
标准起重高度 Standard lifting height	米 m	2.5	2.5	2.5	2.5	3	3	3	3
试验载荷 Test load	吨 t	0.75	1.5	2.25	3	4.5	7.5	12.5	25
两钩间最小距离 Hmin Headroom(hook to hook)Hmin	毫米 mm	270	270	368	444	486	616	700	1000
满载时手链拉力 Chainpull to lift full load	牛顿 N	225	309	343	314	343	383	392	392
起重链行数 No. of load chain fall lines		1	1	2	2	2	2	4	8
起重链条圆钢直径 Diameter of load chain	毫米 mm	6	6	6	6	8	10	10	10
		120	142	178	142	178	210	358	580
		108	122	139	122	139	162	162	189
		24	28	34	34	38	48	64	82
		120	142	178	142	178	210	210	210
净重 Net weight	公斤 kg	10	10	14	14	19	33	70	150
装箱毛重 Gross weight	公斤 kg	11	11	15	15	20	34	75	160
装箱尺寸 (长×宽×高) Packing measurement(L*W*H)	厘米 cm	26×28×20	26×28×20	30×20×17	30×20×17	40×28×20	45×29×23	54×46×22	70×46×75
起重高度每增加1米所增加的重量 Extra weight per meter of extra lift	公斤 kg	1.7	1.7	2.3	2.5	3.7	5.3	9.7	19.4

HSH-VL型手扳葫芦 HSH-VL Series lever hoist

HSH-VL型手扳葫芦是一种小型、多用途手动起重、牵引机械，广泛地应用于电力、矿山、造船、建筑、运输、邮电等部门的设备安装、物品起吊、机件牵引、散件捆绑、线路拉紧及焊接对位等场合，尤其在狭小的工作场所、野外高空作业和各种不同角度的牵拉更显示其优越性。

HSH-VL Series Lever Hoist is hoist a kind of portable and versatile hand-operated loading and pulling appliance, which is capable of being applied in electricity, mines, ship buildings, construction-sites, transports, post and telecommunication for installing equipment, lifting goods, pulling mechanical parts, bulk strapping and fastening, tightening fittings of wires, assembling and welding etc. It has exceptional advantages particularly for pulling in every limited narrow places, in the upper air high above the ground and at any angles.



· 技术参数 Technical parameters

型号 Model	单位 Unit	HSH3 / 4	HSH ¹ / ₂	HSH3	HSH6
起重量 Capacity	吨 t	0.75	1.5	3	6
起升高度 Lifting Height	米 m	1.5	1.5	1.5	1.5
两钩间最小距离 Hmin Headroom(hook to hook)Hmin	毫米 mm	310	370	485	600
满载时手扳力 Fill load hand force	牛顿 N	196	220	325	343
起重链行数 No. of load chain fall lines		1	1	1	2
起重链条圆钢直径 Diameter of load chain	毫米 mm	6	8	10	10
净重/毛重 G/W/N.W.	公斤 kg	6/7	10/11	17/18	27/28
装箱尺寸(长×宽×高) Packing measurement(L×W×H)	厘米 cm	33×15×15	52×19.5×15	52×20×20	52×20×20
起重高度每增加1米所增加的重量 Extra weight per meter of extra lift	公斤 kg	0.82	1.43	2.21	4.42

HSH 型手扳葫芦 HSH Series lever hoist

· 特点

HSH系列环链手扳葫芦主要机件选用优质钢材制造，在设计及使用性能上具有以下特点：

- 1、安全可靠、经久耐用。
- 2、性能好、维修简便。
- 3、体积小、重量轻、携带方便。
- 4、手扳力小、效率高。
- 5、结构先进、外形美观。

Features:

The main parts of the HSH series endless chain lever block are of good quality steel. It has the following features in design and usage performance.

1. Reliable and durable
2. Good performance and easy to maintain
3. Small, light and easy to carry
4. Need small hand force and efficient
5. Advanced in structure and have beautiful appearance



· 技术参数 Technical parameters

型号 Model		HSH0.75T	HSH1.5T	HSH3T	HSH6T	HSH9T
起重量 Capacity (kg)		750	1500	3000	6000	9000
标准起重高度 Standard lifting height		1.5	1.5	1.5	1.5	1.5
试验载荷 Testing load (kg)		1125	2500	4500	7500	11250
满载时手扳力 Force for Full Load		250	310	410	420	420
起重链条规格 load chain	行数 Falls	1	1	1	2	3
	链条圆钢直径 Diameter mm	6.3	7.1	9	9	9
两钩间最小距离 Hmin Headroom	H mm	440	550	650	650	780
手柄长度 Handle Length	D mm	285	410	410	410	410
净重/毛重 N.W/G.W(KG)		6/7	10/11	18/19	28/29	78/80
装箱尺寸(长×宽×高) Packing measurement(L×W×H)	厘米 cm	36×15×15	47×20×22	49×22×24	49×22×24	54×51×28

链条索具 Chain Rigging

G80起重链条 Grade 80 Lifting chain



型号 Model	宽度 Width		单位长度重量 Weight/mtr	极限工作载荷 Max Working Load	实验载荷 Testing Load	最小破断载荷 Min Breaking Load
	最小内宽 Minimum Inside Width	最小外宽 Minimum Outside Width				
6*18	7.5	21	0.79	1.1	27	45.5
7*21	9	24.5	1.07	1.5	37	61.6
8*24	10	28	1.38	2	48	80.4
10*30	12.5	35	2.2	3.2	76	125
12*36	12.6	36.5	2.33	3.8	92	154
12*36	15	42	3.1	4.6	109	181
12.5*38	15.5	42.2	3.3	4.9	117	196
13*39	16.3	46	3.8	5	128	214
14*42	18	49	4.13	6.3	150	250
15*50	17	48	4	6.3	150	250
15*46	20	52	5.17	7	168	280
16*48	20	56	5.63	8	192	320
16*49	24.5	59.5	5.71	8	192	320
16*64	23.9	58.9	5.11	8	192	320
18*54	23	63	6.85	10	246	410
18*54	21	60	6.6	10	246	410
19*57	23.7	63.2	7.7	11.3	270	450



链条索具 (双脚) Chain Rigging(Double Feet)

型号 type	80206	80207	80208	802010	802013	802016	802020	802022	802026	802032
链条直径(mm) Diameter of chain	6	7	8	10	13	16	20	22	26	32
工作载荷(t) rated load (0°C < a ≤ 90°C)	1.60	2.12	2.80	4.25	7.50	11.20	17.00	21.20	30.00	45.00
工作载荷(t) rated load (90°C < a ≤ 120°C)	1.12	1.50	2.00	3.15	5.30	8.00	12.50	15.00	21.20	31.50
长度L(m) length	1.5	1.5	1.5	1.5	2.0	2.5	3.0	3.0	3.0	3.0
1L x 1W(mm)	120 x 70	140 x 80	140 x 80	160 x 95	180 x 105	240 x 140	250 x 150	300 x 180	410 x 220	490 x 265
包装(只/箱) packing per carton	5	4	4	2	1	1	1	1	1	1



链条爪钩 Chain with hooks

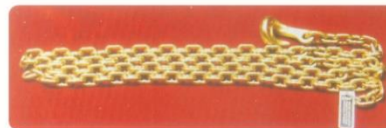

型号 model	链条长度 Chain length	起重量 Capacity
7.1Φ	2.8M	1.5t
10Φ	4M	3.5t
10Φ	6M	3.7t

液压叉车 Hydraulic forklift



货号		ZW20518-H1	ZW20518-H2	ZW20518-H3	ZW20518-T1	ZW20518-T2	ZW20518-T3	
额定起重量	kg	1000	1000	1000	1500	1500	1500	
起升高度	mm	90-2000	90-2500	90-3000	90-2000	90-2500	90-3000	
货叉长度	mm	1150	1150	1150	1150	1150	1150	
货叉外宽(固定)	mm	560	560	560	560	560	560	
载荷中心距	mm	600	600	600	600	600	600	
转弯半径	mm	1600	1600	1600	1600	1600	1600	
起升速度	mm/次time	≥16	≥16	≥16	≥12	≥12	≥12	
下降速度		可控	可控	可控	可控	可控	可控	
外形尺寸	全长	mm	1650	1650	1650	1650	1650	
	全宽	mm	760	760	760	760	760	
	全高	mm	1500	1770	2020	1500	1770	2020
	前轮外径	mm	80	80	80	80	80	80
后轮外径	mm	150	150	150	150	150	150	
自重	kg	268	276	297	276	285	305	

手动搬运车 Hand truck



货号		ZW10083-W1	ZW10083-W2
额定载重	kg		2500
货叉最低高度	mm		85
货叉最高高度	mm		205
单个货叉宽度	mm		160
货叉整体宽度	mm	680	540
货叉长度	mm	1200	1150
净重	kg		75

电动液压搬运车 Electric hydraulic truck

- 1、电动搬运车有着提高货物搬运效率、减轻劳动强度的特点。
- 2、由人力通过能力液压系统来实现托盘货物的起升和下降，并由能力驱动完成搬运作业。
- 3、托盘运输工具中最简单、最有效、最常见的装卸、搬运工具。
- 4、广泛应用于车间、药厂、仓库、楼上作业、窄道作业、远距离搬运。

1. Electric truck has the characteristics of improving cargo handling efficiency and reducing labor intensity.
2. The lifting and dropping of pallet goods is realized by manpower through the capacity hydraulic system, and the handling operation is completed by capacity driving.
3. The simplest, most effective and most common tools for loading, unloading and handling of pallet carriers.
4. Widely used in workshop, pharmaceutical factory, warehouse, upstairs operation, narrow path operation, remote handling.

型号	单位	1.6T	2.5T
额定载荷	kg	1600	2500
货叉最低高度	mm	80	80
货叉最高高度	mm	190	190
大轮尺寸	mm	180×50	180×50
小轮尺寸	mm	70×80	70×80
货叉外宽	mm	550/685	550/685
货叉长度	mm	1200	1200
重量	kg	90	90
电池电压、额定容量	/	48V12A	48V15A
运行速度，装载/空载	/	5.3/5.8	5.3/5.8
电机功率	W	350	350



OCS-A 通用型电子吊秤

产品特点

- ◆ 优质合金钢载荷部件
- ◆ 精密压铸铝机壳
- ◆ 字高30mmLED显示屏
- ◆ 字高30mmLCD背光显示屏
- ◆ 高强度活动式吊环
- ◆ 高强度环眼型吊钩
- ◆ 大容量充电电池
- ◆ 不锈钢面板按键
- ◆ 红外遥控器
- ◆ 系列规格：1000kg~2000kg

主要技术指标

准确度等级	OIML III级
去皮范围	100% F.S.
置零范围	4% F.S.
安全载荷	120% F.S.
极限载荷	400% F.S.
超载报警值	100% F.S. + 9e
电池规格	6V/10Ah
连续使用时间	> 100h
充电器规格	9V/1500mA
遥控器距离	≥ 10m
温度范围	-10℃~40℃



平衡器 Balancer

弹簧平衡器主要借助于蜗卷弹簧蓄积的能量，使所悬挂的外载荷在空中外于“悬浮”状态，使弹性势能与重力达到平衡，这就是弹簧平衡器工作的基本原理，因此弹簧平衡器是一种专门与操作工具配套使用，而不可缺少的辅助用具。远藤（ENDO）弹簧平衡器广泛应用于汽车，客车，机车，船舶，家用电器，建筑，矿上，油田，机器制造等领域中，无论在流水生产线或各种形式的工检上，凡是使用手动工具及吊携装备的场合都可使用弹簧平衡器，从而大大减轻作业人员的劳动强度，提高生产效率，并有助于实现文明生产。

spring balancer is mainly by the energy accumulation volute spring coil, the suspension loads in the air in the state, the elastic suspension balance and gravitational potential energy, and it is spring balancer is the basic principle of work, therefore, is a spring balancer tool supporting the use of special and operation, and the auxiliary appliance indispensable. Far cane (ENDO) spring balancer is widely used in cars, buses, locomotive, shipping, household appliances, building, emeralds, oil fields, machine manufacture, whether in the assembly lines or various forms of workers who use manual inspection, tools and equipment of the occasions with crane can use spring balancer is greatly reduced, and homework personnel from the labor intensity, improve the production efficiency, and helps achieve production.



弹簧平衡器规格 Specification

序号 Code	型号 Model	平衡器载荷(kg) Capacity (kg)	钢丝绳伸 (m) Length of wire-rope (m)	自重 (kg) Self-weight (kg)
1	END0-9	4.5-9	1.3	3.6
2	END0-15	9-15	1.3	4
3	END0-22	15-22	1.6	7.4
4	END0-30	22-30	1.6	7.8
5	END0-40	30-40	1.6	10
6	END0-50	45-50	1.6	10.6
7	END0-60	50-60	1.6	11.8
8	END0-70	60-70	1.6	12
9	END0-80	70-80	1.6	12.5
10	END0-90	80-90	1.6	13
11	END0-100	90-100	1.6	13
12	END0-120	100-120	1.6	14

永磁吸盘 Permanent Magnetic lifter



钢材厚度		负载能力之比率					
mm	inch	YS-3000	YS-2000	YS-1000	YS-600	YS-400	YS-100
T1	up 60 up 2.36"	100%	100%	100%	100%	100%	100%
T2	55	2.16"	95%	100%	100%	100%	100%
T3	50	1.97"	90%	95%			
T4	45	1.77"	85%	90%			
T5	40	1.57"	80%	85%			
T6	35	1.38"	70%	75%	90%		
T7	30	1.18"	60%	65%	80%		
T8	25	0.98"	50%	55%	70%	90%	
T9	20	0.79"	40%	45%	60%	75%	90%
T10	15	0.59"	30%	35%	50%	60%	70%
T11	10	0.39"	20%	25%	35%	45%	50%
T12	5	0.20"	10%	15%	20%	25%	30%



负载能力及钢材平面粗糙度换算表

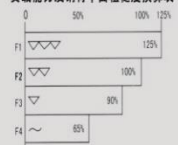

负载能力及钢材之材料种类换算表

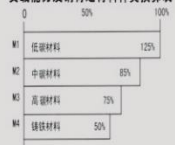

· 最大吊重范围 Maximum lifting range

材料形状 Material shape	钢 板 steel plate				圆 形 钢 材 round steel						
	型号 Type	最大吊重能力 Maximum lifting capacity	最小厚度要求 Minimum thickness	最大吊装能力 Max lifting capacity	最大直径 Max diameter	最大长度 Max length					
YS-100		kg 100	lbs 220	mm 15	inch 0.59"	kg 45	lbs 99	mm 150	inch 5.9"	mm 1000	inch 40"
YS-400		kg 400	lbs 660	mm 25	inch 0.98"	kg 135	lbs 300	mm 250	inch 9.8"	mm 1500	inch 60"
YS-600		kg 600	lbs 1320	mm 30	inch 1.18"	kg 270	lbs 600	mm 350	inch 13.8"	mm 2000	inch 80"
YS-1000		kg 1000	lbs 2200	mm 40	inch 1.57"	kg 450	lbs 990	mm 450	inch 17.8"	mm 2500	inch 98"
YS-2000		kg 2000	lbs 4400	mm 55	inch 2.16"	kg 900	lbs 1980	mm 550	inch 21.6"	mm 3000	inch 118"
YS-3000		kg 3000	lbs 6600	mm 60	inch 2.36"	kg 1350	lbs 2970	mm 650	inch 25.6"	mm 3500	inch 138"

机械千斤顶 Mechanical jack

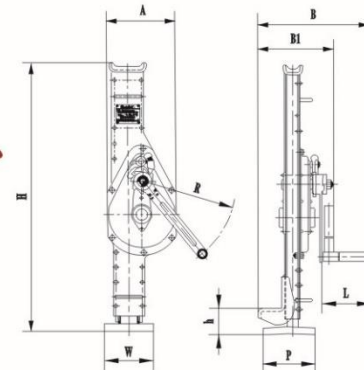

型号 Model		QJC-1.5A	QJC-3A	QJC-5A	QJC-10A	QJC-16A	QJC-20A
额定起重量 Rated Capacity	t	1.5	3	5	10	16	20
试验载荷 Test Load	KN	18.4	36.8	61.3	122.5	196	245
起升高度 Lift distance	mm	350	350	300	300	400	400
最低起顶高度 Lift distance	上拖架 Upper-bracket	mm	725	725	725	800	950
	下拖架 Lower-bracket	mm	70	75	75	85	110
手柄旋转半径 R The handle turning radius R	mm	250	250	250	300	300	300
外形尺寸 Dimensions	mm						
	A	125	185	192	220	380	380
	B	286	304	330	472	510	510
	BI	188	204	232	254	300	300
	H	722	724	724	796	950	950
	h	68	72	74	82	110	110
	L	130	130	130	250	250	250
W	130	130	150	150	200	200	
P	140	140	170	170	230	230	
净重 Net weight	kg	13	20	27	43	91	91

单轨行车系列

一、GCL-SK 手拉单轨行车

GCL-SK Geared trolley

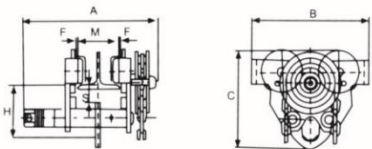

· 性能参数表 Performance parameter list

型号	Model		GCL0.5	GCL1	GCL1.5	GCL2	GCL3	GCL5	GCL10	
额定载重量	Capacity	吨t	0.5	1	1.5	2	3	5	10	
试验载荷	Test load	吨t	0.735	1.471	2.206	2.942	4.413	6.129	12.258	
能通过的最小弯道半径 The smallest crankle radius which can gate through		米m	0.9	1	1	1.1	1.3	1.4	1.7	
主要尺寸	Dimensions	毫米mm	A	242.5	245	279.5	179.5	344	362	402
			B	170	206	228	240	282	327	389
			C	187	206	236	243	321	393	490
			H	105	109	125	133	179	220	275
			F	≈3	≈3	≈3	≈3	≈3	≈3	
推荐用工字钢	I-steel available	毫米mm	68-94	68-100	88-118	94-124	116-140	142-180	142-180	
净重	Net weight	公斤Kg	11.8	14.7	17.5	17.5	34.5	53	88	

二、GCT-SK 手推单轨行车

GCT-SK plain trolley

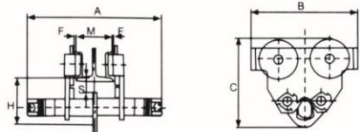

· 性能参数表 Performance parameter

型号	Model		GCT0.5	GCT1	GCT1.5	GCT2	GCT3	GCT5	GCT10	
额定载重量	Capacity	吨t	0.5	1	1.5	2	3	5	10	
试验载荷	Test load	吨t	0.735	1.471	2.206	2.942	4.413	6.129	12.258	
能通过的最小弯道半径 The smallest crankle radius which can gate through		米m	0.9	1	1	1.1	1.3	1.4	1.7	
主要尺寸	Dimensions	毫米mm	A	177	194	235	235	275	338	362
			B	170	206	228	240	282	327	389
			C	187	206	236	243	321	393	490
			H	105	109	125	133	179	220	275
			F	≈3	≈3	≈3	≈3	≈3	≈3	
推荐用工字钢	I-steel available	毫米mm	68-94	68-100	88-118	94-124	116-140	142-180	142-180	
净重	Net weight	公斤Kg	4.8	7.7	12.8	12.8	34.5	43	88	

吊装带系列

吊装带 Lifting belt

圆状环形吊索



异型圆状吊索 (I)



孪生 (异型) 圆状吊索 (II)



保护套筒



扁平吊装带



单组合
Single



双组合
Double



三组合
Tribble



四组合
Forble

- ※ 材料: 聚脂、尼龙。
- ※ 安全系数: 6: 17: 18: 1
- ※ 标准: 国际标准ISO4807 欧洲标准EN1492—2
- ※ 长度: 按照客户要求
- ※ 颜色: 色码
- ※ Material: Polyester、Nylon
- ※ Safe factor: 6: 17: 18: 1
- ※ Standard: IOS4807 EN1492-2
- ※ Length: According to customer request
- ※ Color: color code

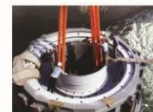

起重吊钳系列

起重吊钳

Derrick pliers

· 特点:

外形美观, 使用方便, 维护简便。
加紧迅速, 工效高。
设有自锁装置, 工作安全可靠。

· FEATURES:

The clamps have self-lock device, secure and reliable.
The clamps can clamp quickly and efficiently.
They are beautiful, easy to use and convenient to maintain.



JCD系列垂直钢板夹钳
JCD Series vertical Lifting Clamps



JPD系列水平钢板夹钳
JPD Series Horizontal lifting Clamps



PPD系列水平钢板夹钳
PPD Series Horizontal Clamps

型号 Model	额定载重量 Standard Capacity	试验载荷 Testing Load	钳口夹持宽度 Jaw opening	净重 Weight
JCD-1	1	2000	0-22	3.6
JCD-2	2	4000	0-30	6.0
JCD-3	3	6000	0-35	9.2
JCD-5	5	10000	5-45	16.5

型号 Model	钳口夹持宽度 Jaw opening	额定载重量 Standard Capacity	试验载荷 Testing Load	主要尺寸 Critical Dimensions				净重 Weight
				A	B	C	D	
JPD-1.0	3-18	1000	2000	175	150	50	44	2
JPD-2.0	3-22	2000	4000	230	180	70	60	4.4

型号 Model	钳口夹持宽度 Jaw opening	额定载重量 Standard Capacity	试验载荷 Testing Load	净重 Weight
PPD-0.75	0-25	750	1500	3
PPD-1.5	0-30	1500	3000	4
PPD-2.0	0-45	2000	4000	6

起重滑车系列

滑车系列

Pulley block series

名称 Description	型号 Model	额定起重量(t) Standard Capacity	试验载荷(KN) Testing Load	钢丝绳直径 (mm) Wire Rope Dia		轮槽直径(mm) Sheave Dia	机体重量(kg) Weight
				适用 适用	最大 最大		
链环型滑车单轮开口吊钩 Sing Wheel Open Hook Pulley	HQGLRK1-0.5	0.5	8	6.2	7.7	71	1.75
	HQGLRK1-1	1	16	7.7	11	85	3.25
	HQGLRK1-2	2	32	11	14	112	6
	HQGLRK1-3.2	3.2	51.2	12.5	15.5	132	10.5
	HQGLRK1-5	5	80	15.5	18.5	160	19
2轮吊钩链环型滑车 Double Wheels Hook Pulley	HQGL2-8	8	128	20	23	210	35.2
	HQGL2-10	10	160	23	24.5	240	50.5
	HQGL2-16	16	224	28	31	315	113.5
	HQGL2-20	20	280	31	35	355	162.2
	HQGL2-1	1	16	6.2	7.7	71	3.15
3轮吊钩链环型滑车 Triple Wheels Hook Pulley	HQGL3-2	2	32	7.7	11	85	6
	HQGL3-3.2	3.2	51.2	11	14	112	11
	HQGL3-5	5	80	12.5	15.5	132	20
	HQGL3-8	8	128	15.5	18.5	160	35
	HQGL3-10	10	160	17	20	180	47
4轮吊钩链环型滑车 Four Wheels Hook Pulley	HQGL4-8	8	128	15.5	18.5	160	35
	HQGL4-10	10	160	17	20	180	47
	HQGL4-16	16	224	23	24.5	240	75.2
	HQGL4-20	20	280	26	28	280	138.9
	HQGL4-32	32	448	31	35	355	237.5
5轮吊钩链环型滑车 Five Wheels Hook Pulley	HQGL5-3.2	3.2	51.2	7.7	11	85	8.2
	HQGL5-5	5	80	11	14	112	16.83
	HQGL5-8	8	128	12.5	15.5	132	18
	HQGL5-10	10	160	15.5	18.5	160	47
	HQGL5-16	16	224	17	20	190	49.79
6轮吊钩链环型滑车 Six Wheels Hook Pulley	HQGL6-20	20	280	20	23	210	69.59
	HQGL6-32	32	448	26	28	280	187.8
	HQGL6-50	50	700	31	35	355	360

名称 Description	型号 Model	额定起重量(t) Standard Capacity	试验载荷(KN) Testing Load	钢丝绳直径 (mm) Wire Rope Dia		轮槽直径(mm) Sheave Dia	机体重量(kg) Weight
				适用 适用	最大 最大		
4轮吊环型滑车 Four Wheels Stationary Ring Pulley	HQD4-8	8	128	11	14	112	29.36
	HQD4-10	10	160	12.5	15.5	132	41.46
	HQD4-16	16	224	15.5	18.5	160	76.23
	HQD4-20	20	280	17	20	180	84
	HQD4-32	32	448	23	24.5	240	196.23
5轮吊环型滑车 Five Wheels Stationary Ring Pulley	HQD5-10	10	160	17	20	180	347.9
	HQD5-20	20	280	15.5	18.5	160	91.5
	HQD5-32	32	448	20	23	280	303
6轮吊环型滑车 Six Wheels Stationary Ring Pulley	HQD6-80	80	1040	31	35	355	277.5
	HQD6-100	100	1300	31	35	355	516.5
	HQD6-120	120	1560	31	35	355	691.3
8轮吊环型滑车 Eight Wheels Stationary Ring Pulley	HQD8-80	80	1040	26	28	280	530
	HQD8-100	100	1300	28	31	315	653.5
	HQD8-160	160	2080	31	35	355	1137.4
	HQD8-200	200	2500	34	38	400	1360
	HQD8-250	250	3125	34	38	400	2037
10轮吊环型滑车 Ten Wheels Stationary Ring Pulley	HQD10-200	200	2500	31	35	355	1552
	HQD10-320	320	4000	40	43	450	2974



三轮吊钩滑车(11-32t)
Triple Wheels Hook Pulley



三轮链环滑车(11-32t)
Triple Wheels Link Pulley



四轮吊环滑车
Four Wheels Stationary Ring Pulley



六轮吊环滑车
Six Wheels Stationary Ring Pulley



单轮吊钩滑车(0.51-20t)
Single Wheel Hook Pulley



单轮链环滑车(0.51-20t)
Single Wheel Link Pulley



单轮吊钩滑车(0.51-20t)
Single Wheel Hook Pulley



双轮吊钩滑车(11-32t)
Double Wheels Hook Pulley